

SME Series datasheet

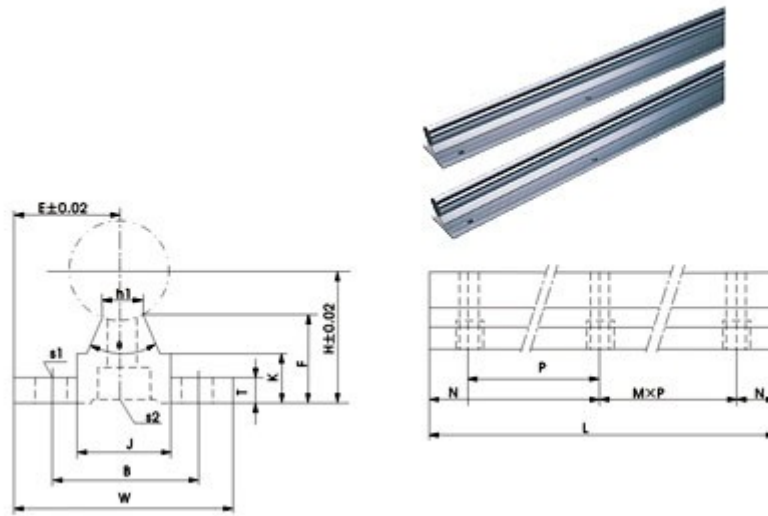

MODEL NO.	SHAFT DIAMETER	MAIN DIMENSIONS								MOUNTING DIMENSION						WEIGHT(kg)
		H	E	W	L	F	T	K	J	h1	θ	B	N	M × P	S1	
SBR12	12	20.46	17	34		15	4.5	9.8	15	6	80°	25	50		4.5	M4
SBR-16	16	25	20	40		17.8	5	11.7	18.5	8	80°	30		5.5	M5	
SBR-20	20	27	22.5	45		17.7	5	10	19	8	50°	30		5.5	M6	
SBR-25	25	33	27.5	55		21	6	12	21.5	8	50°	35		6.5	M6	
SBR-30	30	37	30	60		22.8	7	13	26.5	10.3	50°	40		6.5	M8	